

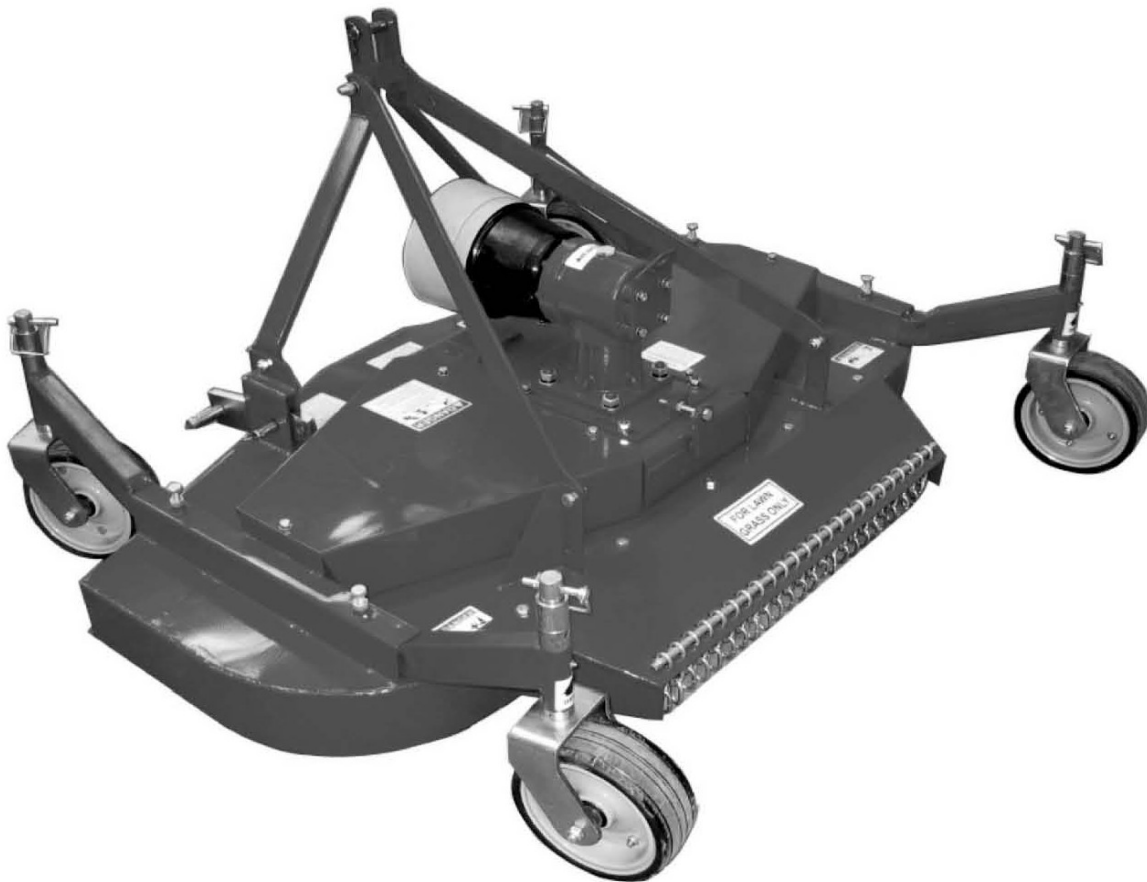

# Operator's Manual

## BFM-105 & BFM-106 Finishing Mowers



## **TABLE OF CONTENTS**

SAFETY INFORMATION .....	2
SAFETY SIGNS .....	6
ASSEMBLY INSTRUCTIONS .....	9
OPERATION INSTRUCTIONS .....	11
MAINTENANCE INSTRUCTIONS .....	14
TROUBLESHOOTING GUIDE .....	17
PARTS LIST AND EXPLODED VIEW .....	19

### **TO THE CUSTOMER**

**This manual contains valuable information about your new Mower. It has been carefully prepared to give you helpful suggestions for operating, adjusting, and servicing.**

**Keep this manual in a convenient place for quick and easy reference. Study it carefully, only by proper care and operation can you expect to receive the service and long life designed and built into this mower.**

**It is the owner's and/or operator's responsibility to....**

- **Read and understand the information contained in this manual.**
- **Operate, lubricate, assemble and maintain the equipment in accordance with all instructions and safety procedures in this manual.**
- **Inspect the equipment and replace or repair any parts that are damaged or worn which could cause damage, wear to other parts, or cause a safety hazard.**

# SAFETY INSTRUCTIONS



## SAFETY SIGNS

Keep safety signs clean and legible at all times.

Do not paint over, remove or deface any safety signs or warning signs on your equipment. Observe all safety signs and practice the instruction on them.

Replace safety signs that are missing or have become illegible.

Replaced parts that displayed a safety sign should also display the current sign.

Safety signs are available from your Distributor.

### **HOW TO INSTALL SAFETY SIGNS:**

Be sure that the installation area is clean and dry.

Be sure temperature is above 50°F (10°C).

Decide on the exact position before you remove the backing paper.

Remove the smallest portion of the split backing paper.

Align the sign over the specified area and carefully press the small portion with the exposed sticky backing in place.

Slowly peel back the remaining paper and carefully smooth the remaining portion of the sign in place.

Small air pockets can be pierced with a pin and smoothed out using the piece of sign backing paper.



## EQUIPMENT SAFETY GUIDELINES

Safety of the operator is one of the main concerns in designing and developing a new piece of equipment. Designers and manufacturers build in as many safety features as possible. However, every year many accidents occur which could have been avoided by a few seconds of thought and a more careful approach to handling equipment. You, the operator, can avoid many accidents by observing the following precautions in this section. To avoid personal injury, study the following precautions and insist those working with you, or for you, follow them.

In order to provide a better view, certain photographs or illustrations in this manual may show an assembly with a safety shield removed. However, equipment should never be operated in this condition. Keep all shields in place. If shield removal becomes necessary for repairs, replace the shield prior to use.

Never use alcoholic beverages or drugs which can hinder alertness or coordination while operating this equipment. Consult your doctor about operating this machine while taking prescription medications.

Review the safety instructions with all users annually. This equipment is dangerous to children and persons unfamiliar with its operation. The operator should be a responsible adult familiar with farm machinery and trained in this equipment's operations. **Do not allow persons to operate or assemble this unit until they have read this manual and have developed a thorough understanding of the safety precautions and of how it works.**

To prevent injury or death, use a tractor equipped with a Roll-Over Protective System (ROPS).

Never exceed the limits of a piece of machinery. If its ability to do a job, or to do so safely, is in question - **DON'T TRY IT.**

Do not modify the equipment in any way. Unauthorized modification may impair the function and/or safety and could affect the life of the equipment.

In addition to the design and configuration of this implement, including Safety Signs and Safety Equipment, hazard control and accident prevention are dependent upon the awareness, concern, prudence, and proper training of personnel involved in the operation, transport, maintenance, and storage of the machine. Refer also to Safety Messages and Operation Instructions in each of the appropriate sections of the Tractor and Mower Manuals. Pay close attention to the Safety Signs affixed to the Tractor and the Mower.



## **SAFETY TRAINING**

Safety is a primary concern in the design and manufacture of our products. Unfortunately, our efforts to provide safe equipment can be wiped out by a single careless act of an operator.

In addition to the design and configuration of equipment, hazard control and accident prevention are dependent upon the awareness, concern, prudence and proper training of personnel involved in the operation, transport, maintenance and storage of equipment.

It is the operator's responsibility to read and understand ALL Safety and Operating instructions in the manual and to follow them. Accidents CAN be avoided.

Working with unfamiliar equipment can lead to careless injuries. Read this manual and the manual for your tractor before assembling or operating your mower, to acquaint yourself with the machines. It is the rotary mower owner's responsibility if this machine is used by any person other than yourself, to make certain that the operator, prior to operating:

1. Reads and understands the operator's manuals.
2. Is instructed in safe and proper use.

Know the controls and how to stop tractor, engine, and mower quickly in an emergency. Read this manual and the one provided with your tractor.

Train all new personnel and review instructions frequently with existing workers. A person who has not read and understood all operating and safety instructions is not qualified to operate the machine. An untrained operator exposes himself and bystanders to possible serious injury or death.

Do not allow children to operate this machine.



## **PREPARATION**

Never operate the tractor and mower until you have read and completely understand this manual, the Tractor Operator's Manual, and each of the Safety Messages found on the safety signs on the tractor and mower.

Personal protection equipment including hard hat, safety glasses, safety shoes, and gloves are recommended during assembly, installation, operation, adjustment, maintaining, repairing, removal, or moving the implement. Do not wear loose clothing, gloves, neckties, rings, bracelets, or other jewelry which may get caught in moving parts. Wear protective hair covering to contain long hair.

### **PROLONGED EXPOSURE TO LOUD NOISE MAY CAUSE PERMANENT HEARING LOSS!**

Tractors with or without Mowers attached can often be noisy enough to cause permanent, partial hearing loss. We recommend that you wear hearing protection on a full-time basis if the noise in the Operator's position exceeds 80db. Noise over 85db on a long-term basis can cause severe hearing loss. Noise over 90db adjacent to the Operator over a long-term basis may cause permanent, total hearing loss. **NOTE:** Hearing loss from loud noise (from tractors, chain saws, radios, and other such sources close to the ear) is cumulative over a lifetime without hope of natural recovery.

Operate the mower only with a tractor equipped with an approved Roll-Over Protective System (ROPS). Always wear your seat belt on tractors equipped with a ROPS. Serious injury or even death could result from falling off the tractor - particularly during a turnover when the operator could be pinned under the ROPS or the tractor.

Clear area to be cut of stones, branches or other debris that might be thrown, causing injury or damage.

Operate only in daylight or good artificial light.

Ensure mower is properly mounted, adjusted and in good operating condition.

Make sure driveline spring-activated locking pin operates freely and is seated firmly in tractor PTO stub shaft groove.

Ensure that all safety shielding and safety signs are properly installed and in good condition.



## **OPERATIONAL SAFETY**

The use of this equipment is subject to certain hazards which cannot be protected against by mechanical means or product design. All operators of this equipment must read and understand this entire manual, paying particular attention to safety and operating instructions, prior to using. If there is something in this manual you do not understand, ask your supervisor, or your dealer, to explain it to you.

Most accidents occur because of neglect or carelessness. Keep all helpers and bystanders at least several hundred feet from an operating rotary mower. Only properly trained people should operate this machine.

When this machine is operated in populated areas or in other areas where thrown objects could injure persons or property, standard equipment safety chain shielding (which is designed to reduce the possibility of thrown objects) must be installed. **Operation must be stopped when anyone comes within 100 yards (300 feet).**

The majority of accidents involve entanglement on the driveline, injury of bystanders by objects thrown by the rotating blades, and operators being knocked off the tractor by low hanging limbs and then being run over by the mower. Accidents are most likely to occur with machines that are loaned or rented to someone who has not read the owner's manual and is not familiar with a rotary mower.

Check the tractor master shield over the PTO shaft. Make sure it is in good condition and fastened securely to the tractor. Purchase a new shield if old shield is damaged or missing.



## **STARTING AND STOPPING SAFETY**

Mower operating power is supplied from tractor PTO. Refer to your tractor manual for PTO engagement and disengagement instructions. Always operate the tractor PTO in the 540 rpm speed selection. **DO NOT OVER SPEED!** Know how to stop tractor and mower quickly in case of an emergency.

When engaging PTO, the engine RPM should always be low. Once engaged and ready to start cutting, raise PTO speed to approx. 540 RPM and maintain throughout cutting operation.

Always stop the tractor, set brake, shut off the tractor engine, remove the ignition key, lower implement to the ground and allow cutter blades to come to a complete stop before dismounting tractor. **Never leave equipment unattended with the tractor running or with implement in raised position.**



## **STORAGE SAFETY**

Following operation, or when unhooking, stop the tractor, set the brakes, disengage the PTO, shut off the engine and remove the ignition keys.

Store the unit in an area away from human activity.

Do not park equipment where it will be exposed to livestock for long periods of time. Equipment damage and livestock injury could result.

Do not permit children to play on or around the stored unit.

Make sure all parked machines are on a hard, level surface and engage all safety devices.

If blocking is used, make sure it is solid and secure before leaving area.



## **MAINTENANCE SAFETY**

Make sure there is plenty of ventilation. Never operate the engine of the towing vehicle in a closed building. The exhaust fumes may cause asphyxiation.

Before working on this machine, drive to a level area, disengage the PTO, lower implement (or if working underneath, raise and block securely), shut off the engine, set the brakes, and remove the ignition keys.

Be certain all moving parts on attachments have come to a complete stop before attempting to perform maintenance.

Never work under equipment unless it is blocked securely. Never depend on hydraulic system to keep implement in raised position.

Keep all persons away from operator control area while performing adjustments, service, or maintenance.

Always use personal protection devices such as eye, hand and hearing protectors, when performing any service or maintenance.

Frequently check mower blades. They should be sharp, free of nicks and cracks and securely fastened.

Periodically tighten all bolts, nuts and screws and check that all cotter pins are properly installed to ensure unit is in a safe condition.

When completing a maintenance or service function, make sure all safety shields and devices are installed before placing unit in service.

After servicing, be sure all tools, parts and service equipment are removed.

Check to ensure all safety signs are installed and in good condition. (See safety sign section for location drawing.)

Do not allow grease or oil to build up on any deck or platform.

Where replacement parts are necessary for periodic maintenance and servicing, genuine factory replacement parts must be used to restore your equipment to original specifications. The manufacturer will not claim responsibility for use of unapproved parts and/or accessories and other damages as a result of their use.

If equipment has been altered in any way from original design, the manufacturer does not accept any liability for injury or warranty.

A fire extinguisher and first aid kit should be kept readily accessible while performing maintenance on this equipment.



## **TRANSPORT SAFETY**

Comply with state and local laws governing highway safety and movement of farm machinery on public roads.

The use of flashing amber lights is acceptable in most localities. However, some localities prohibit their use. Local laws should be checked for all highway lighting and marking requirements.

When driving the tractor and equipment on the road or highway under 20 mph at night or during the day, use flashing amber warning lights and a slow moving vehicle (SMV) identification emblem.

Always be sure the implement is in the proper raised position for transport.

Reduce speed when transporting mounted implements to avoid bouncing and momentary loss of steering control.

Plan your route to avoid heavy traffic.

### **Do not drink and drive!**

Watch for traffic when operating near or crossing roadways.

Use extreme care and maintain minimum ground speed when transporting on hillside, over rough ground and when operating close to ditches or fences. Be careful when turning sharp corners. Turn curves or go up or down hills only at a low speed and at a gradual steering angle. Make certain that at least 20% of the tractor's weight is on the front wheels to maintain safe steerage. Slow down on rough or uneven surfaces, and loose gravel.

Never allow riders on either tractor or mower.

Be a safe and courteous driver. Always yield to oncoming traffic in all situations like narrow bridges and intersections.

# SAFETY SIGN LOCATIONS

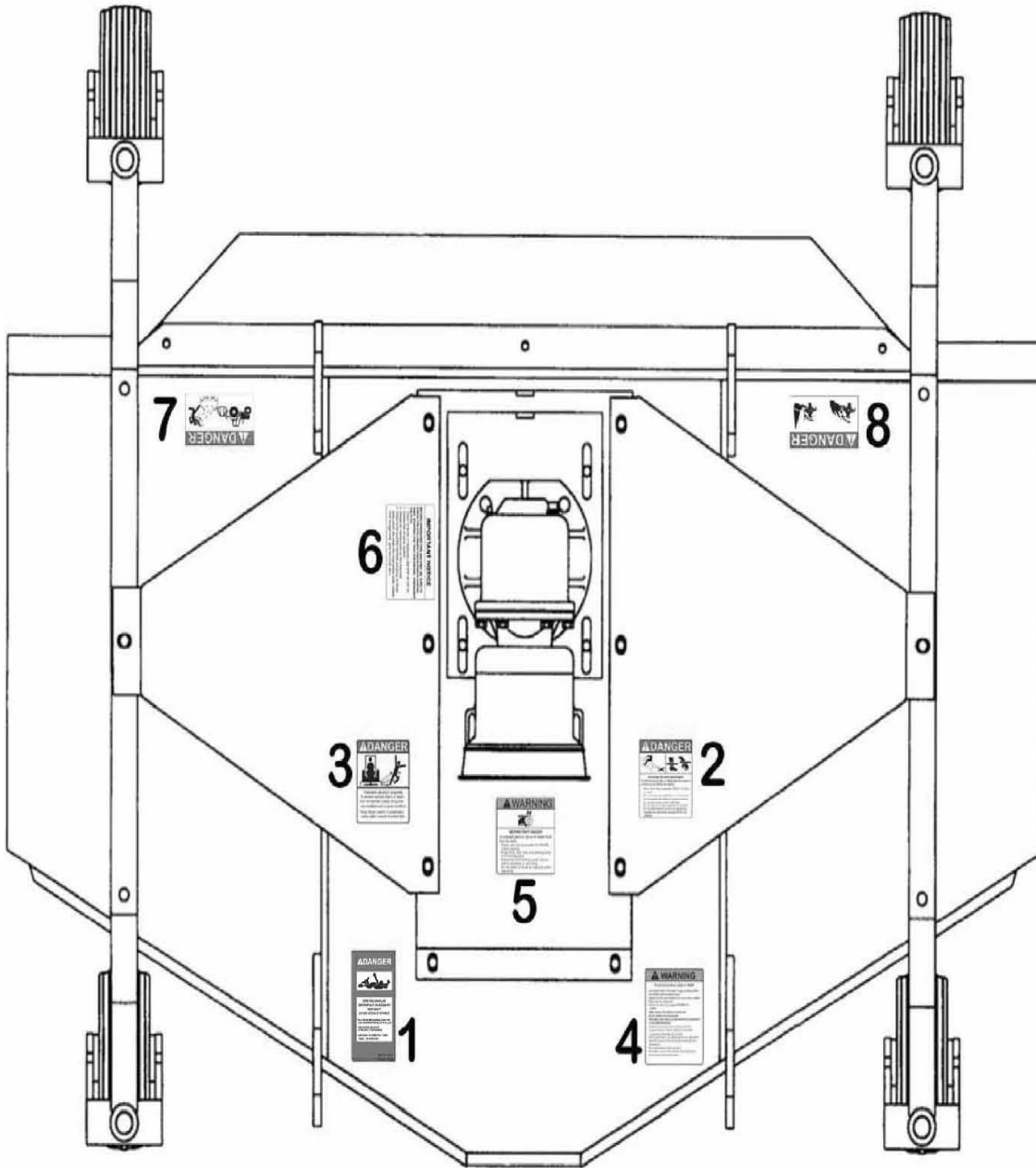



1



2



3



4



**! WARNING**



**MOVING PART HAZARD**

To prevent serious injury or death from moving parts:

- Close and secure guards and shields before starting.
- Keep hand, feet, hair and clothing away from moving parts.
- Disconnect and lockout power source before adjusting or servicing.
- Do not stand or climb on machine when operating

5

**IMPORTANT NOTICE**

**BEFORE OPERATING THIS MACHINE, BE SURE TO CHECK THE FOLLOWING CHECK-POINTS (HAVING FIRST STOPPED THE TRACTOR ENGINE, DISENGAED THE P.T.O.)**

1. Check oil levels (if necessary add SAE 90 EP oil)
2. Grease the driveline spiders.
3. Grease all marked point on the machine.
4. Check to be sure the nut/bolts are snug on those parts which are under the most stress (lines, blades, front linkage bolts, gear box bolts, etc.).

6

**! DANGER**



MIN. 160 ft.

7

**! DANGER**



8

## FINISHING MOWER ASSEMBLY INSTRUCTIONS

**Step 1** Attach the rear brace bars to the lugs on the rear of the deck with an M12 bolt and locking nut. Attach the A-frame bars to the lugs on the front of the mower deck with M12 bolts and locking nuts. See below and right.

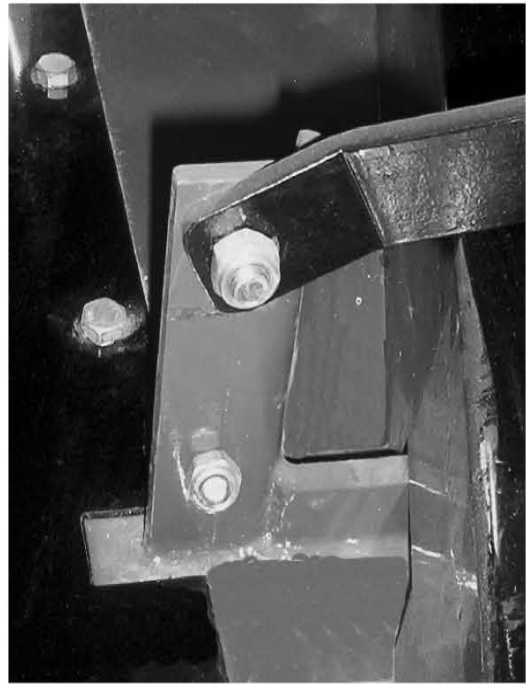

**Step 2** Connect all braces at the top of the A-frame with an M12 bolt, spacer, hitch connection, and locking nut. See figure at right.

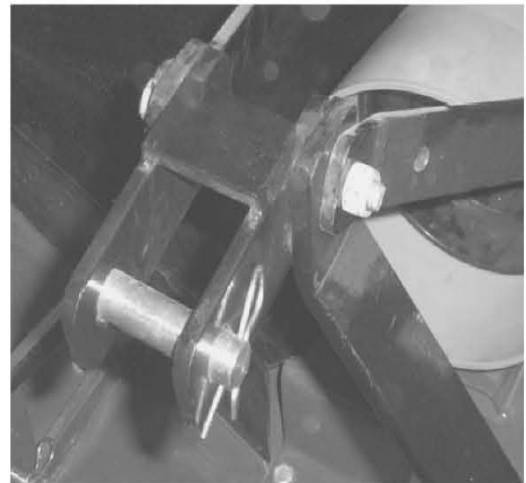

**Step 3.** Install the wheel support braces with M12 bolts and locking nuts as shown below.

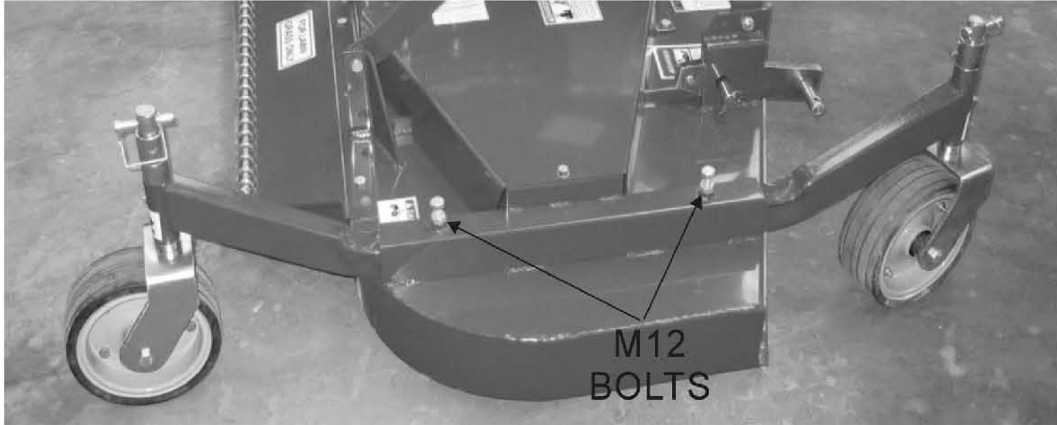

**Step 4.** Install rear discharge chute and safety chains using M12 bolts and locking nuts. See figure below.

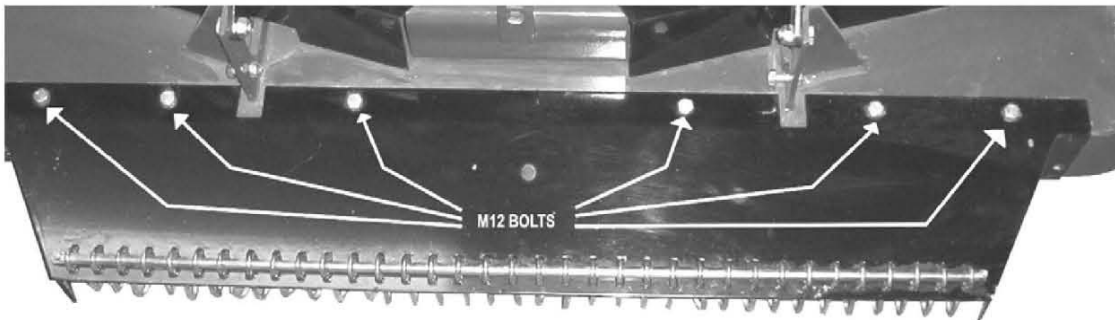

**Step 5.** Adjust the height of the mower deck by installing spacers (A, B, or C) on the bottom of the wheel assembly shaft (2) before inserting into axle arm (3). See figure at right.

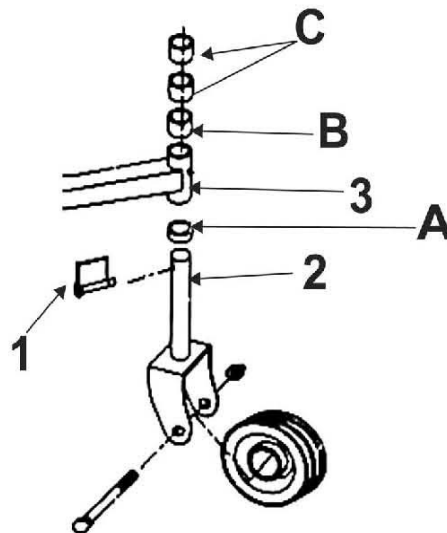

## **OPERATION INSTRUCTIONS**

**The safe operation of this mower is the responsibility of the operator.** The operator should be familiar with the machine, tractor and all safety practices before starting operation. This mower is designed for lawn and grass mowing. It is not designed for rough conditions or heavy mowing. The mower is equipped with suction type blades, which are best suited for lawn mowing.

**Always operate tractor PTO at 540RPM.**

This chapter provides information for attaching mower to tractor and preparing it for field operation. Review this data prior to tractor hookup and operation.

### **TRACTOR PREPARATION**

**Do not install mower on a tractor over 40 HP.**

#### **WARNING**

**Do not operate tractor with less than 20% of its gross unballasted mass on the front wheels with the mower in the transport position.**

#### **WHEEL TREADS**

Tractor wheel tread spacing should be increased when working on inclines or rough ground to reduce the possibility of tipping.

#### **STABILIZER BARS AND SWAY BLOCKS**

Use stabilizer bars or sway blocks to prevent side sway of the mower.

#### **DRAWBAR**

Shorten or remove the tractor drawbar so it will not interfere with the up and down movement of the mower.

#### **WARNING!**

**Do not get between tractor and mower when the engine is running.**

### **ATTACHING THE MOWER TO TRACTOR (LIFT TYPE ONLY)**

This mower is designed for tractors with 540 RPM and category I hitch. Back the tractor up to the mower so that the lower draft arms are in alignment with the mower lift pins. Stop the engine, lock the brakes or place the tractor in park. Connect the tractor and stabilizer bars to the lower lift pins. Adjust the top link so it will pin to the top holes in the A-Frame or into the holes in the floating top link.

#### **DANGER**

**Never allow children to operate, ride or come close to the mower or tractor. Usually, 15-16 year old children who are mature and responsible can operate the mower with reasonable safety if they have read the operator's manual, been trained in safe operation of the machine, and are physically large and strong enough to reach and operate the controls easily.**

### **DRIVELINE ATTACHMENT TO TRACTOR**

1. Slide yoke onto the tractor PTO shaft.
2. Move yoke back and forth until locking pin has engaged on the PTO shaft groove.

#### **WARNING**

**When attaching the driveline yoke to the tractor PTO shaft, it is important that the spring activated locking pin seats properly in the tractor PTO shaft groove.**

### **CUTTING HEIGHT ADJUSTMENT**

#### **WARNING!**

**Avoid personal injury! Be sure tractor engine is off, that key is removed from ignition and allow blades to completely stop turning before dismounting to make adjustments.**

**Important:** Avoid very low cutting heights. Striking the ground with the blades gives the most damaging shock loads a mower can encounter and will cause damage to it and the driveline.

1. Using the tractor, raise the mower off the ground and place supports underneath of it, so that it will not drift downwards while making adjustments or maintenance.
2. While supporting the wheel and yoke assembly off the ground, remove the snapper pin from the top of the gauge wheel spindle. Position the supplied spacers as required for achieving the desired cutting height.

## **OPERATION INSTRUCTIONS (continued)**

### **TRACTOR REQUIREMENTS AND PREPARATION**

This Finishing Mower is designed for light duty cutting such as lawn maintenance with a Category I, 3 pt. hitch and with a 540 rpm PTO. This mower is not designed for tractors over 40 horsepower. The PTO must be in good working condition.

It is recommended that only tractors with wide front axles be used with this cutter. Tricycle front wheel arrangements are inherently unstable and tractor rollover accidents are more likely to occur.

Tractor wheel tread spacing should be increased when working on inclines or rough ground to reduce the possibility of tipping.

The tractor also needs lift arm stabilizer bars or sway blocks to control side movement of the cutter.

Check the tractor's 3 pt. hydraulic lift system. Refer to your tractor operator's manual or dealer for any adjustments necessary to put the hydraulic system in good working order.

Be sure tires and rims are in good condition. Inflate tires to the proper recommended air pressure.

Check the tractor master shield over the PTO shaft. Make sure it is in good condition and fastened securely to the tractor. Purchase a new shield if old shield is damaged or missing.

It is recommended that a ROPS (Roll-Over Protection System) and a seat belt be installed on all tractors. Contact your local dealer for a ROPS for your tractor.

### **CAUTION!**

**Be sure your tractor is in good condition. Read all the safety precautions and make sure all tractor operators are familiar with the safety rules of operation.**

The operator is responsible for the safe operation of this mower. The operator must be properly trained. Operators should be familiar with the mower and tractor and all safety practices before starting operation. Read the safety rules and safety signs before operation.

Recommended mowing speed for most conditions is from two to five mph.

### **WARNING!**

**When using the unit, a minimum 20% of tractor and equipment weight must be on tractor front wheels. Without this weight, tractor could tip up, causing possible loss of control and possible personal injury or death. The weight may be attained with a front end loader, front wheel weights, ballast in tires or front tractor weights. When attaining a minimum 20% of tractor and equipment weight on the front wheels, you must not exceed the ROPS weight certification. Weigh the tractor and equipment. DO NOT GUESS OR ESTIMATE!**

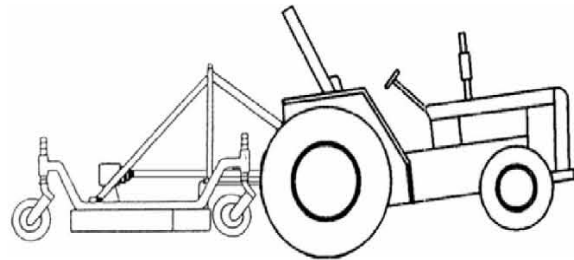

### **WARNING!**

**A heavy load can cause instability in driving a tractor. Make sure the front of the tractor is properly counterbalanced with weights. Always drive slowly - especially around turns. An unstable tractor could steer badly and possibly tip over, causing injury or death.**

### **DANGER!**

**For non-agricultural applications, OSHA, ASAE SAE and ANSI standards require the use of chain guards, deflectors or solid skirts at all times. The mower manufacturer strongly recommends the use of chain guards, rubber belting or solid skirts for agricultural applications as well, to reduce the risk of property damage, serious bodily injury or even death from objects thrown or from contact with the cutting blades.**

Front, rear, left and right are determined by the normal direction of travel, the same as when driving an automobile.

# OPERATION INSTRUCTIONS (continued)

## STARTING AND STOPPING MOWER

The power required for operating the mower is supplied via the tractor PTO. Refer to your tractor's manual for instructions on engaging and disengaging the PTO.

1. Always engage the PTO at low engine RPM.
2. Operate the mower at 540 RPM PTO speed. Do not exceed 540 RPM PTO speed.
3. In case of emergency, you must learn how stop the tractor and mower quickly.

**Important:** Stop cutter and tractor immediately upon striking an obstruction. Inspect the mower and repair any damage before resuming operation. Do not disengage PTO when the engine is at full PTO RPM. Always bring the tractor engine to idle speed before disengaging the PTO.

### **WARNING!**

**Avoid personal injury! When attempting to stop a tractor which does not have a live PTO, the momentum created by the blades of a mower can cause the tractor to be pushed forward. Do not operate this mower unless the tractor has a live or independent PTO.** To start operation, reduce engine speed and engage the tractor PTO. Before starting to cut, gradually increase the engine speed to develop full PTO speed. Enter the area to be cut with the cutter operating at PTO speed and, if it becomes necessary to temporarily regulate engine speed during operation, increase or decrease the speed gradually. To transport the mower, disengage the PTO and raise to full transport height.

### CUTTING SPEED

Proper ground speed for cutting will depend upon the height, type, and density of the grass to be cut.

Normally, ground speed will range from 1.5 to 3 MPH. Tall dense grass should be cut at low speeds, while thin medium height grass can be cut at faster ground speeds.

### CUTTING TIPS

Always operate the PTO at the recommended RPM when cutting. This is necessary for correct blade speed, which creates a clean and even grass cut. Under certain conditions the tractor tires may roll some grass blades down and prevent them from being cut at the same height as the surrounding area. If this occurs, reduce the tractor ground speed, but maintain 540 RPM PTO speed. The lower ground speed will allow grasses to be at least partially rebound and cut. Taking a partial cut and/or reversing the direction of travel may also produce a cleaner cut. When people are passing by the area you are cutting, stop the cutting until the area has been cleared.

Although the mower is shielded to prevent objects from being thrown by the blades, no shielding device is 100% effective. The mower operator has greater knowledge of the hazards created by the machine than people on the street. Therefore, he must take every precaution possible when other people are around.

### **WARNING!**

**Avoid personal injury! Pick up all rocks and other debris before cutting. Enter new cutting areas carefully. Cut material higher the first time to allow the mower to clear unseen or hidden objects. Never assume that a cutting area is clear. Always check carefully.**

Extremely tall grass should be cut in two stages. First, raise the mower above the desired cutting height and cut the grass in one direction. Second, adjust the mower to the desired cutting height and cut in a perpendicular (90 degree) direction from the first cut.

Before cutting analyze the area to determine the best cutting procedure. One must consider the grass height, its type and the terrain relief.

Grass is best cut when it is dry. Mowing wet grass can cause plugging, which results in grass clumps behind the mower.

## DETACHING AND STORING

Lower the mower to the ground. Park the tractor with transmission in the correct gear (Automatic transmissions should be set on Park; Standard transmissions should be set on Neutral). Set the parking brake, turn off the engine and remove the keys from the ignition. Wait until the PTO stops rotating completely before dismounting the tractor. Disconnect the driveline from the tractor PTO and store it to prevent contact from the ground and away from excessive moisture. Always reinstall or lower into position the tractor PTO master shield. This shield should always remain in place except when connecting or disconnecting the driveline.

## BEFORE OPERATING OR TRANSPORTING THE MOWER

Always display the SMV (slow moving vehicle) symbol on the rear of the tractor that transports the mower. The SMV symbol should be clearly visible to vehicles overtaking the tractor transporting the mower. Prominent display of this symbol will help the operator avoid accidents which could cause injury or possibly death.

**See figure at right.**



# MAINTENANCE INSTRUCTIONS

Before operating the mower, make sure that it is properly lubricated and thoroughly inspected. Only a minimum of time and effort is required to regularly lubricate and maintain it. Following a regular program will provide long life and trouble free operation.

## WARNING!

**Always disengage the tractor PTO before raising the mower for transport or making adjustments.**

## LUBRICATION

Do not let excess grease collect on or around parts, particularly when operating in sandy areas. The illustration below and on the next pages, show the location of all the lubrication fittings.

Use an SAE multi-purpose, lithium type grease for all the locations shown **on figure 9**. Be sure to clean the grease fittings before applying any grease. Daily lubrication of the driveline U-joints is necessary. Failure to maintain proper lubrication will result in premature wear and damage to the U-joints, gearbox and/or driveline.

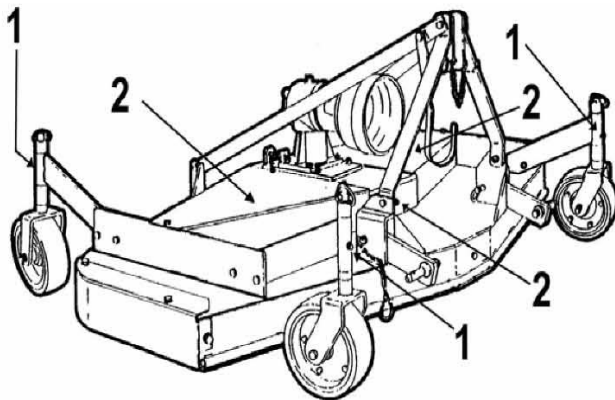

Figure 9

Lubrication fitting location

Item	Description	Frequency*
1	Gauge wheel pivots	Every 8 hours or daily
2	Blade spindle	Every 8 hours or daily
N/S	U-joints	Every 8 hours or daily

Lubrication intervals shown are for mowers operating under normal conditions. Severe or unusual conditions may require more frequent lubrication.

## GEARBOX LUBRICATION

**The gearbox must be filled with SAE 90 EP oil before operating.**

To fill gearbox to the correct operating level:

1. Place the mower on an even and leveled surface.
2. Remove filler and test level plug (See **figure** below for location of plugs).
3. Add oil through the filler plug until it starts running out of the test plug. (Pour oil slowly to make sure that the lower portion of the gearbox housing has been filled)
4. Screw the test and filler plugs back in their corresponding places.

It is recommended that the oil level plug be removed after every 8-10 hours of operation and oil added until it runs out of the test plug hole. The filler plug hole and test plug hole are both located on the back of side of the gearbox.

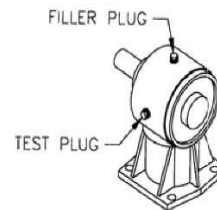

### Note:

1. It is recommended that the test plug be removed after every 8-10 hours of operation, and oil added to the proper fill level if required.
2. Do not overfill the gearbox with oil. This will result in pressure build up inside the unit, which can cause the oil seals to leak.
3. If the gearbox suddenly starts making an unusual noise, stop at once, check for oil leaks and refill it as required.

## GAUGE WHEEL ASSEMBLIES

The gauge wheels are equipped with bearings which require grease regularly. Grease fittings are provided in the gauge wheel pivot. It is recommended that these be lubricated after every 8 hours of operation.

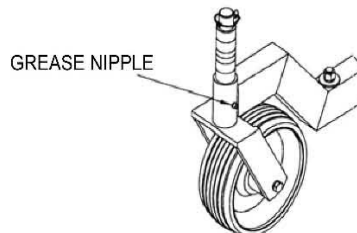

## MAINTENANCE INSTRUCTIONS (continued)

### DRIVELINE LUBRICATION

Grease fittings are located on the cross and bearing kit assemblies of both U-joints. U-joints should be greased after every 8 hours of operation. **See figure below** for the location of the grease fittings. Do not force grease through the needle bearing cup assemblies.

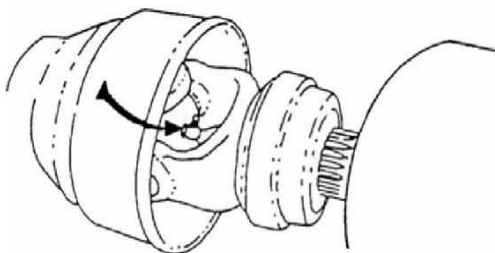

The metal telescoping drive tubes inside the plastic shield tubes must be lubricated before each use. **See figure below.**

Disconnect the driveline from the tractor and pull halves apart (do not disconnect the driveline that is attached to the mower gearbox). Insert grease into drive tube and spread it evenly. Reconnect the two driveline halves together. Reconnect the driveline to the tractor PTO, raise and lower the mower several times so that the grease just applied spreads over the entire working area of the drive tubes.

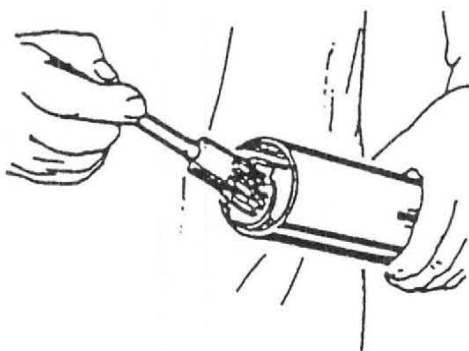

### **WARNING!**

**When attaching the driveline yoke to the tractor PTO shaft, it is important that the spring activated locking pin is seated on the PTO shaft groove. A loose yoke could slip off and result in personal injury or damage to the mower.**

### BLADE SPINDLE LUBRICATION

Blade spindles must be lubricated after every 8 hours of operation. Access the lubrication fittings through the holes in the belt guards. Each spindle is supplied with a grease fitting, and it must be lubricated sufficiently so that a small amount of grease escapes through the bleed hole on their underside. Do not force large amounts of grease on the spindles, as it may get on the drive belts. Grease fittings on front of spindle housing facing front and under the pulley. Both side belt shields need to be removed to lubricate.

### BLADE SERVICING

Use only correct specified blades on your mower. They are manufactured of special heat-treated alloy steel. Substitute blades may not meet specifications and may fail in a hazardous manner, which could cause injury.

### BLADE REMOVAL AND INSTALLATION

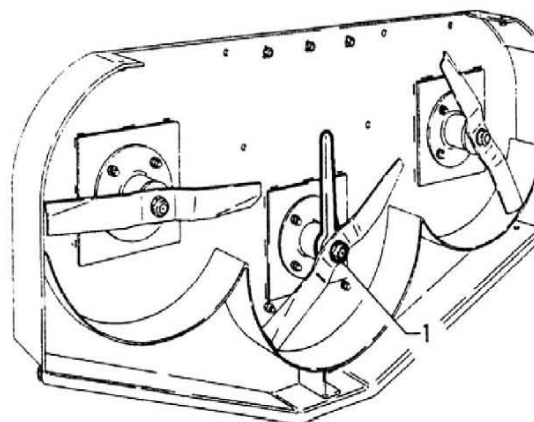

### BLADE REMOVAL AND INSTALLATION

Place the machine at a comfortable height and lock it in position with sufficient support to guarantee the operator's safety.

Prevent the blade rotating by locking the shaft with a wrench (the shaft is designed for this with two flat areas immediately above the blade).

Unscrew the nut (ref. #1, figure above) and remove the blade.

Check the state of wear of the shaft and the nut and, if necessary, replace them.

To install the blade, place the blade and washer on the spindle shaft and screw the nut on fully and tighten securely, keeping the shaft locked at the same time as described above.

**Note:** Always wear heavy leather gloves while tightening blade bolts.



## MAINTENANCE INSTRUCTIONS (continued)

### BLADE SHARPENING

To maintain a proper blade balance, always sharpen both ends of the blade equally. Follow the sharpening pattern as shown in figure below. Do not sharpen the blades to a razor edge, but leave a 1/32" blunt edge. Never sharpen the back side of the blades.

#### **WARNING!**

**Avoid personal injury! Always support or block the mower when servicing the blades, carrier or any other component on the underside of the deck.**

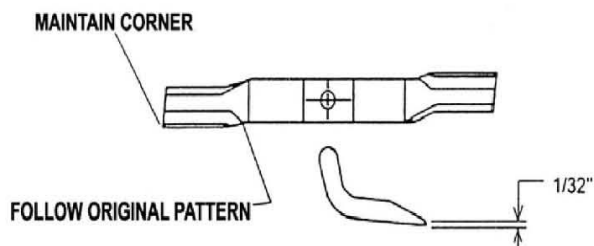

Hold the end of the blade using heavy leather gloves.

### DRIVE BELT ADJUSTMENT

1. Shut off mower and tractor.
2. Loosen all four nuts (Item 1) on the gearbox slide plate (Item 2). See figure in next column.
3. Loosen jam nut (Item 3) on the tension adjustment bolt (Item 4).
4. Tighten adjustment bolt (Item 4) until the belt deflection along the front side of the belts (Items 5 & 6) is 3/4" when approximately 10 pounds of pressure is applied to the center of the belt length.
5. Do not overtighten belts!
6. Tighten jam nut (Item 3) and nuts (Item 1) on gearbox slide plate.

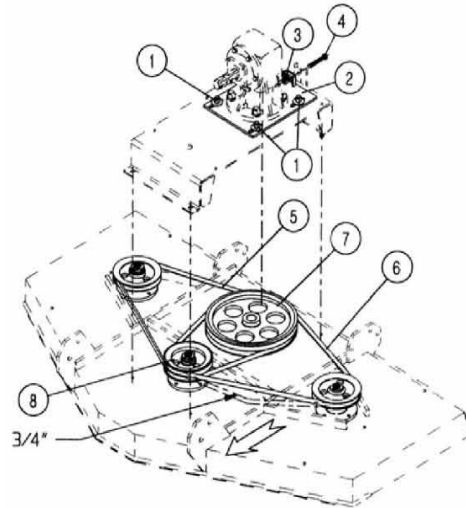

### DRIVE BELT REMOVAL AND INSTALLATION

1. Shut off mower and tractor.
2. Remove drive belt shield fasteners and belt shields.
3. Loosen gearbox slide plate bolts and gearbox adjustment bolt.
4. Slide gearbox to its forward most position.
5. Slide belts under the gearbox sheave (Item 7) and over the center spindle sheave (Item 8).
6. Make sure that right hand belt (Item 5) is in the lower groove of the gearbox sheave and that the left hand belt (Item 6) is in the upper groove.
7. Slide the gearbox back to the full rear position and adjust according to the belt adjustment procedure described above.

### STORAGE

Your mower represents an investment from which you should get the greatest possible benefit and use. Therefore, when the cutting season is over, the mower should be thoroughly checked and prepared for storage so that a minimum amount of work will be required to put it back into operation for the next season.

We suggest the following storage procedures:

1. Thoroughly clean the mower.
2. Lubricate the mower as recommended in the maintenance section of this manual.
3. Tighten all bolts and pins to the recommended torque.
4. Check the mower for worn or damaged parts and replace them.
5. Store the mower in a clean, dry place with the deck resting on blocks.
6. Use spray touch up enamel where necessary to prevent rust and maintain its appearance

# OBHEY ALL SAFETY WARNINGS!!

# TROUBLESHOOTING

PROBLEM	POSSIBLE CAUSE	SOLUTION
Streaking	<ol style="list-style-type: none"> <li>1. Slow blade tip speed</li> <li>2. Worn blade tips</li> <li>3. Dull blades</li> <li>4. Blades unable to cut the part of grass pressed down by tractor's tire path or mower's casters</li> <li>5. Mowing too fast</li> <li>6. Drive belt loose</li> <li>7. Belt glazed/slipping</li> <li>8. Blade loose on spindle</li> <li>9. Conditions too wet for mowing</li> </ol>	<ol style="list-style-type: none"> <li>1. Operate PTO at 540 RPM</li> <li>2. Replace with correct specified blades</li> <li>3. Sharpen blades uniformly</li> <li>4. Slow tractor's ground speed but maintain 540 RPM PTO speed</li> <li>5. Slow down until cured</li> <li>6. Tighten per instructions on maintenance chapter</li> <li>7. Apply belt dressing or replace it with a correct specified belt</li> <li>8. Tighten blade nut securely</li> <li>9. Allow grass to dry before mowing</li> </ol>
Grass discharges from mower unevenly or bunches along a swath	<ol style="list-style-type: none"> <li>1. Grass is too high and too coarse</li> <li>2. Belt slipping</li> <li>3. Grass is wet</li> </ol>	<ol style="list-style-type: none"> <li>1. Slow tractor's ground speed but maintain 540 RPM PTO speed. Raise the mower for the first pass and lower to the desired cutting height for the second and cut at 90 degrees to the first pass. Raise the rear of mower high enough to allow the grass to discharge, but not too high for streaking to occur</li> <li>2. Tighten belt or replace with a correct specified belt</li> <li>3. Allow grass to dry before mowing. Slow tractor's ground speed but maintain 540 RPM PTO speed. Cut the grass at a lower height</li> </ol>
Heavy vibration	<ol style="list-style-type: none"> <li>1. Blade speed is too fast</li> <li>2. Broken/bent blade</li> <li>3. Worn/unbalanced blade</li> <li>4. Bent/broken sheave</li> <li>5. Debris caught on blade</li> </ol>	<ol style="list-style-type: none"> <li>1. Do not exceed 540 RPM PTO speed</li> <li>2. Replace with correct specified blade</li> <li>3. Grind blade uniformly or replace</li> <li>4. Replace with correct specified part</li> <li>5. Clean off blade</li> </ol>
Belt slipping	<ol style="list-style-type: none"> <li>1. Belt loose</li> <li>2. Belt glazed</li> <li>3. Oil on belt</li> </ol>	<ol style="list-style-type: none"> <li>1. Tighten or replace with correct specified belt</li> <li>2. Use belt dressing or replace it</li> <li>3. Clean or replace</li> </ol>
Belt slippage	<ol style="list-style-type: none"> <li>1. Mower is overloading, grass is too tall or heavy</li> <li>2. Oil on belt from over lubrication</li> <li>3. Belt hung or rubbing</li> </ol>	<ol style="list-style-type: none"> <li>1. Slow tractor's ground speed but maintain 540 RPM PTO speed. Cut the grass twice. Raise the mower for the first pass and lower to the desired cutting height for the second and cut at 90 degrees to the first pass. Cut a partial swath only.</li> <li>2. Clean lubricant from belt and sheaves with a clean rag. Replace oil soaked belts. Be sure to follow operator's manual recommendations.</li> <li>3. Check belt for free travel in sheaves. Check under mower deck and spindles for debris or other foreign material and remove if any is present</li> </ol>
Belt rollover	<ol style="list-style-type: none"> <li>1. Damaged belt</li> <li>2. Foreign object in sheave groove</li> <li>3. Worn sheave groove</li> </ol>	<ol style="list-style-type: none"> <li>1. Replace it with correct specified belt</li> <li>2. Inspect all sheave grooves for rust, paint or other foreign material. Remove these if present.</li> <li>3. Replace with correct specified sheave</li> </ol>

## TROUBLESHOOTING (continued)

PROBLEM	POSSIBLE CAUSE	SOLUTION
Damaged belt	Rollover, high shock loads or installation damage	Replace it with correct specified belt
Belt breakage	1. High shock loads 2. Belt came off sheave	1. Avoid hitting ground and large obstructions with the mower. 2. Check sheave for proper alignment and foreign material. Ensure proper belt tension. Avoid hitting the ground and large obstructions with mower
Blade is scraping ground	1. Mower too low 2. Field is ridged 3. Field is too wet	1. Raise mower - reset wheels. 2. Cut field at a different angle 3. Stop and wait until is dried
Gearbox overheating	1. Low on lubricant 2. Improper type lubricant 3. Excessive trash build-up around gearbox	1. Fill to proper level 2. Replace with proper lubricant 3. Remove trash
Gearbox leaking	1. Damaged oil seal 2. Bent shaft 3. Shaft rough in oil seal area 4. Oil seal installed wrong 5. Oil seal not sealing in the housing 6. Oil level too high 7. Hole in gearbox 8. Gasket damaged 9. Bolts loose	1. Replace seal 2. Replace oil seal and shaft 3. Replace or repair shaft 4. Replace seal 5. Replace seal or use a sealant on outside diameter of seal 6. Drain oil to proper level 7. Replace gearbox 8. Replace gasket 9. Tighten bolts
<p><i>NOTE: Since the oil heats, the gearbox may reach a rather high temperature during work and its out surface may become "hot" to touch. This is normal and will cause no damage. It is, however, important to always check that the oil is at the correct level and of the indicated type.</i></p>		
PTO contacts mower front frame when raised	Raising mower too high or incorrect adjustment of tractor top link	Adjust top link or tractor lift stops (See attachments instructions)
Gearbox noisy	1. Worn bearings 2. Low oil in gearbox	1. Replace bearings 2. Check level and add oil
Blades wear too fast	1. Cutting in sandy conditions 2. Cutting in rocky conditions 3. Blades hitting ground	1. Increase cutting height 2. Increase cutting height. Remove rocks 3. Increase cutting height
Mower seems to require excessive power	1. Advancing into grass too rapidly 2. Hitting ground 3. Worn or dull blades 4. Tractor not large enough 5. Grass wet 6. Grass too tall and heavy	1. Reduce forward travel speed 2. Raise mower and reset wheels 3. Sharpen or replace blades 4. Use larger horsepower tractor 5. Allow grass to dry before mowing 6. Slow ground speed of tractor but keep engine running at full PTO rpm. Make two passes. Raise mower for first pass and lower for next pass.
Mower moves from side to side when cutting	Loose tractor sway chains or bars, or sway blocks improperly installed	Adjust sway chains, bars, or sway blocks

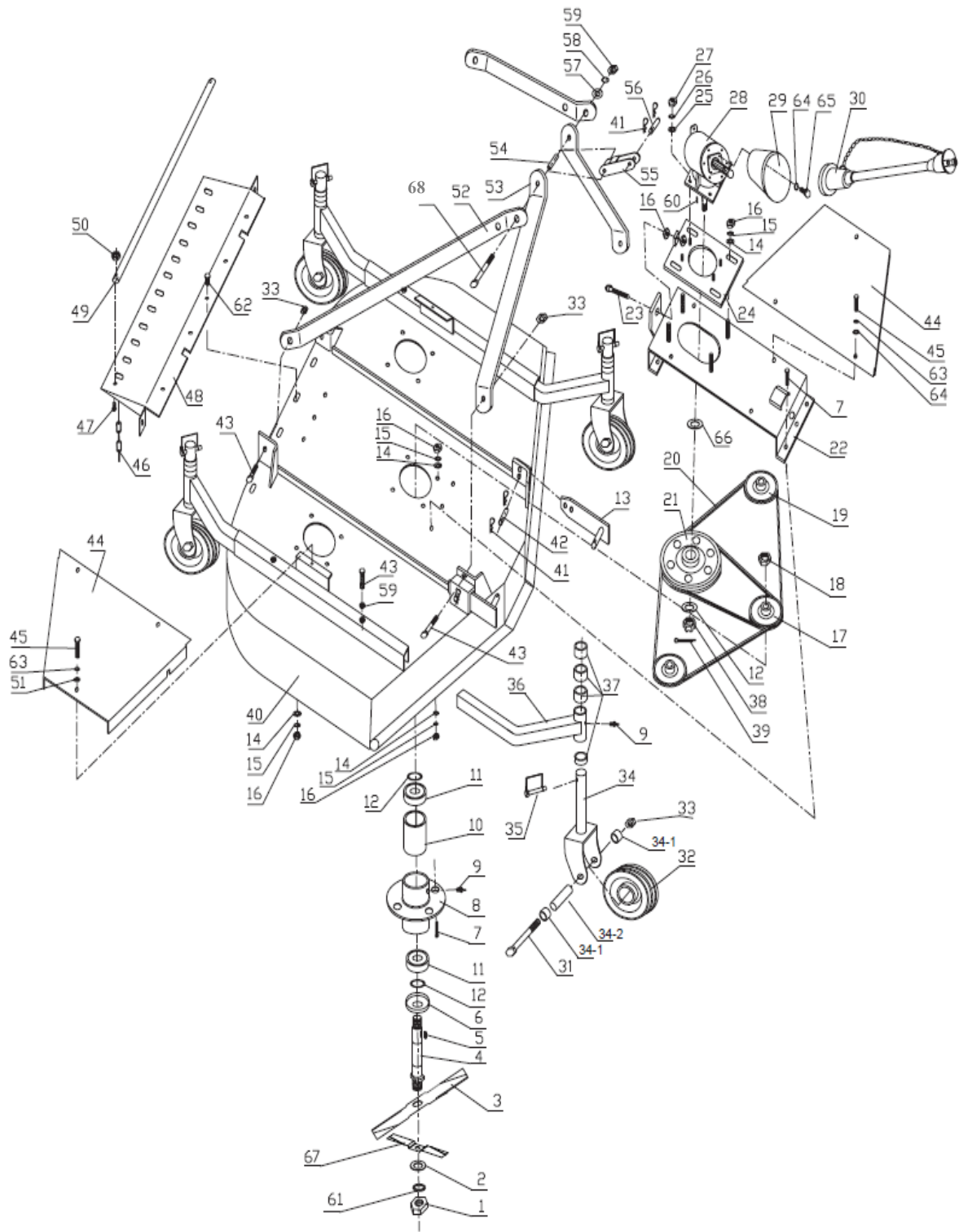

POSITION	PART #	DESCRIPTION	SPECIFICATION	Q'TY
1	LNM1815	Nut M18 X 1.5		3
2	FW18	Flat Washer	18	3
3	FMB4002	Blade	5' - 505 X 50 X 6	3
	FMB4003	Blade	6' - 610 X 60 X 6	3
4	FM10038	Blade Spindle Shaft		3
5	KM080730	Round End Key	8 X 7 X 30	3
6	FM10040	Dust Cap		3
7	BM101530	Bolt	M10 X 1.5 x 30	17
8	FM10041	Bearing Holder		3
9	GN081S	Grease Nipple	8 X 1	7
10	FM10043	Steel Sleeve		3
11	B6205-2RS	Bearing	62052RS	6
12	FW24	Flat Washer	24	7
13	FM10044	Joint Plate	5'	2
	FM10045	Joint Plate	6'	2
14	FW10	Flat Washer	10	5' - 28
	FW10	Flat Washer	10	6' - 29
15	LW10	Lock Washer	10	5' - 28
	LW10	Lock Washer	10	6' - 29
16	NM1015	Nut	M10 X 1.5	5' - 28
	NM1015	Nut	M10 X 1.5	6' - 29
17	FM10046	Double Pulley	5'	1
	FM10047	Double Pulley	6'	1
18	NM2415	Nut	M24 X 1.5	3
19	FM10048	Single Pulley	5"	2
	FM10049	Single pulley	6'	2

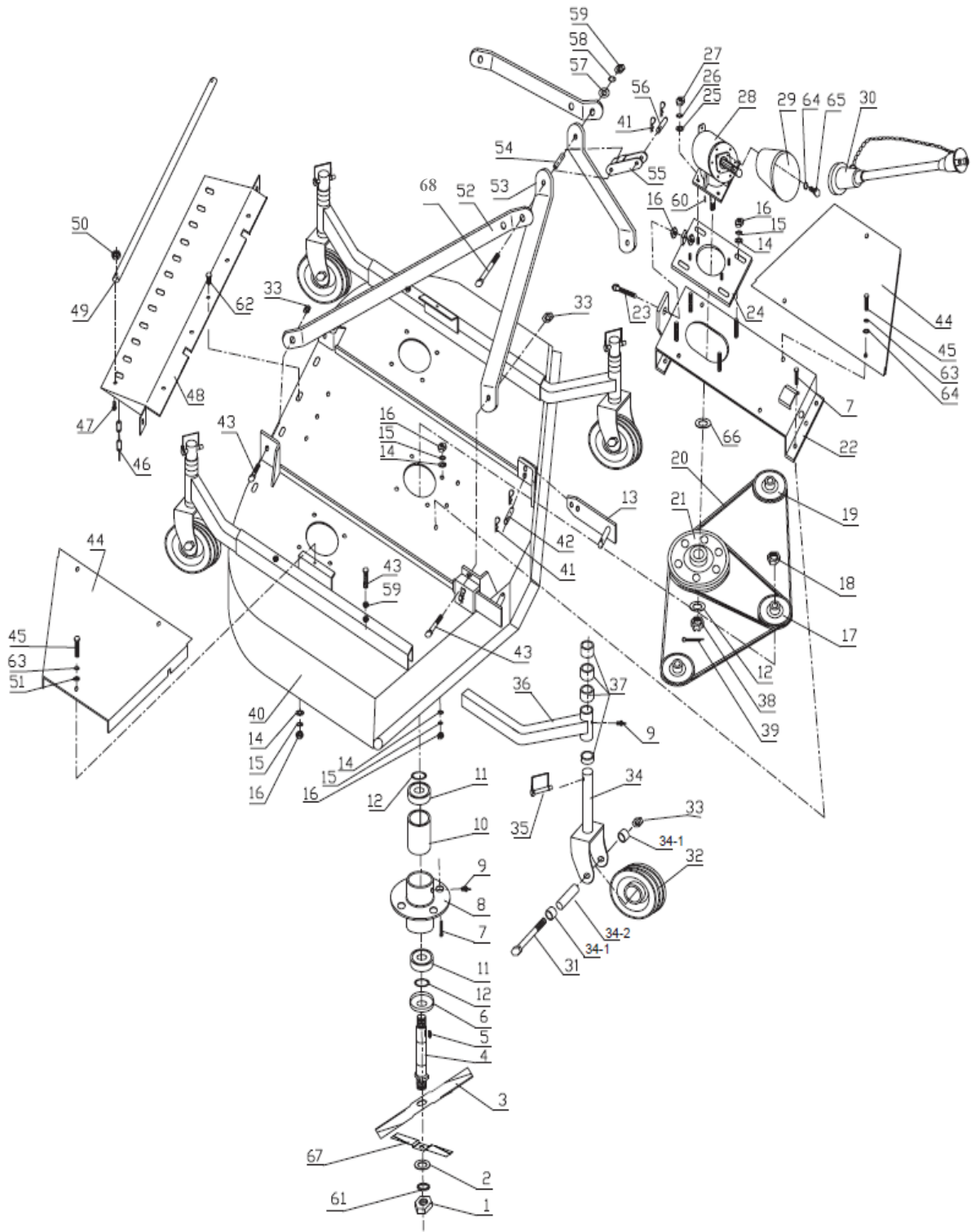

POSITION	PART #	DESCRIPTION	SPECIFICATION	Q'TY
20	FM10051	V-Belt	5' - B1575	
	FM10052	V-Belt	6' - B1880	
21	FM10054	Main Input Pulley	5' & 6'	1
22	FM10056	Gearbox Rest	5' & 6'	1
23	BM101580	Adjusting Bolt	M10 X 1.5 X 80	1
24	FM10057	Sliding Plate		1
25	FW16	Flat Washer	16	4
26	LW16	Lock Washer	16	4
27	NM1620	Nut	M16 X 2.0	4
28	FM10058	Gearbox		1
29	FM10060	Safety Guard		optional
30	FM10062	PTO	5'	1
	FM10063	PTO	6'	1
31	BM1620140	Wheel Axle (Bolt)	M16 X 2.0 X140	4
32	FM10102	Wheel	210 X 80	4
33	LNM1620	Lock Nut	M1620	
34	FM10067	Wheel Yoke		
34-1	FM10108	Wheel Spacer		8
34-2	FM10066	Axle Sleeve		4
35	FM10068	Lock Pin		4
36	FM10071	Formed Axle	5'	
	FM10070	Formed Axle	6'	
37	FM10073	Adjusting Spacer 1/4"		4
	FM10074	Adjusting Spacer 1/2"		4
	FM10075	Adjusting Spacer 3/4"	5'	optional
	FM10103	Adjusting Spacer 1"	6'	4
	FM10105	Adjusting Spacer 1 1/2'		4

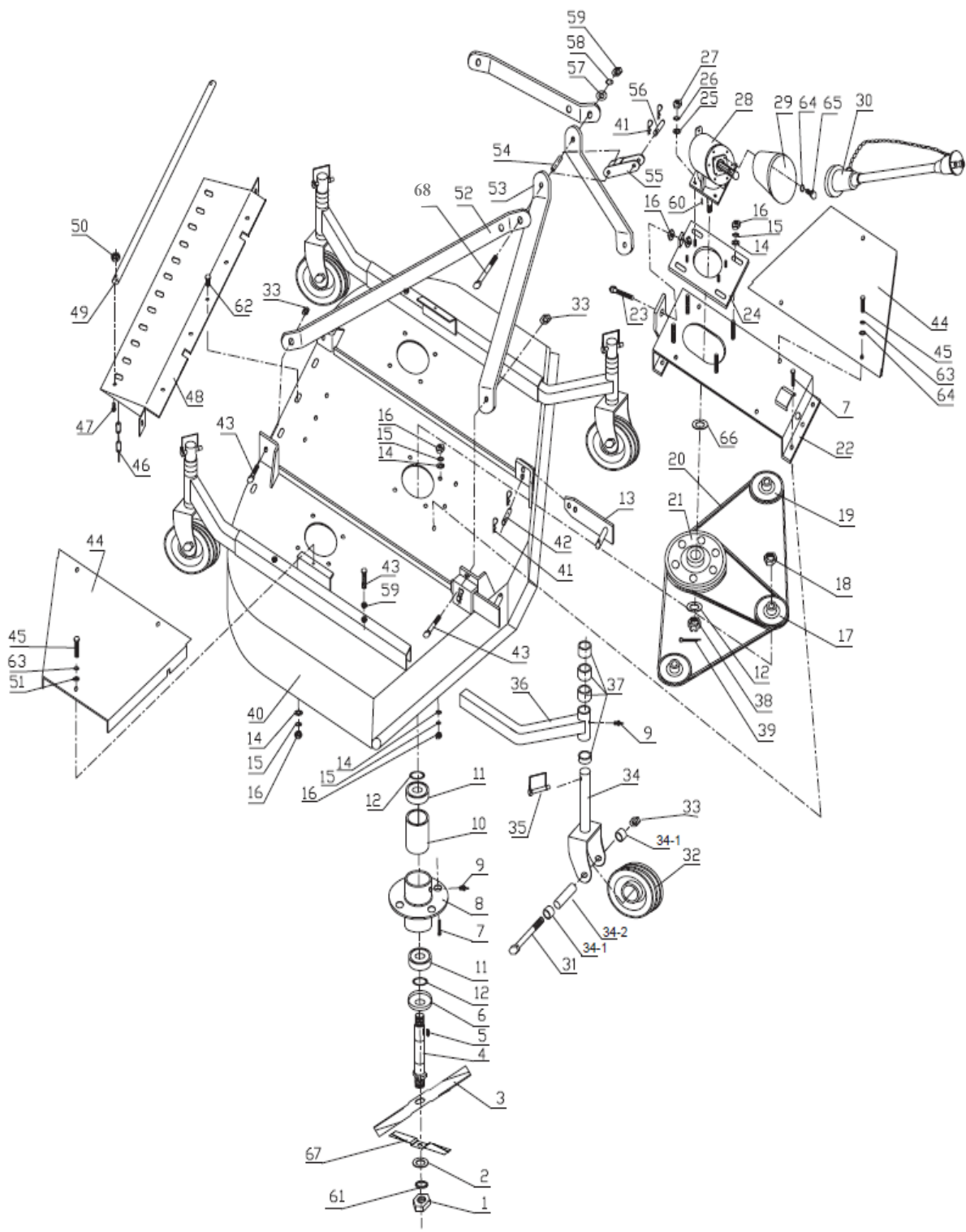



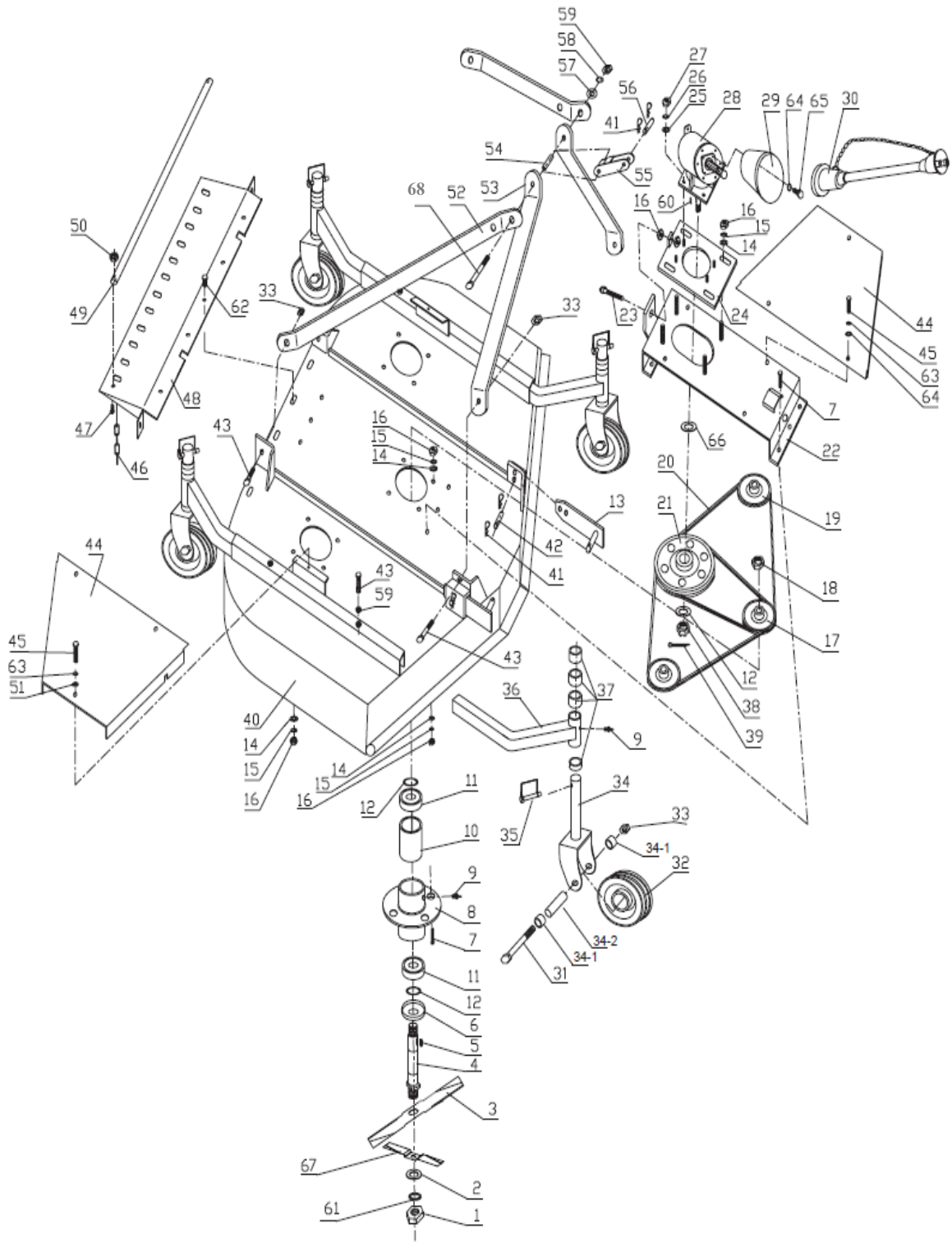

POSITION	Part #	DESCRIPTION	SPECIFICATION	Q'TY
38	CNM242	Gearbox Castle Nut	M24 X 2.0	1
39	CP5X50	Cotter Pin	5 X 50M	1
40	FM10077	Main Deck	5'	1
	FM10078	Main Deck	6'	1
41	FM10079	Hair Pin		6
42	FM10080	Pin	19 X 60.5MM	2
43	BM1217540	Bolt	M12 X 1.75 X 40	8
44	FM10082	Belt Guard	5'	2
	FM10083	Belt Guard	6'	2
45	BM0812515	Bolt	M8 X 1.25 X 15	6
46	FM10085	Chain	5'	24
	FM10086	Chain	6'	35
47	BM061025	Bolt	M6 X 1.0 X 25	2
48	FM10088	Deflector	5'	1
	FM10089	Deflector	6'	1
49	FM10091	Chain Rod	5'	1
	FM10092	Chain Rod	6'	1
50	LN061	Lock Nut	M6 X 1.0	2
51	FW8	Flat Washer	8	6
52	FM10094	Rear Brace	5'	2
	FM10095	Rear Brace	6'	2
53	FM10096	Front Brace		2
54	FM10097	Brace		1
55	FM10098	Upper Hitch		1
56	FM10099	Pin		1
57	FW12	Flat Washer	12	1
58	LW12	Lock Washer	12	1



POSITION		DESCRIPTION	SPECIFICATION	Q'TY
59	NM12175	Nut	M12 X 1.75	5
60	KM100835	Gearbox Key	10 X 8 X 35	1
61	LW18	Lock Washer	18	3
62	BM101525	Bolt	M10 X 1.5 X 25	5' - 7
	BM101525	Bolt	M10 X 1.5 X 25	6' - 8
63	LW08	Lock Washer	8	6
64	FW12	Flat Washer	12	4
65	BM0812512	Bolt	M8 X 1.25 X 12	4
66	FW24	Flat Washer	24	1
68	BM12175130	Bolt	M12 X 1.75 X 130	1
69	FM10101	Blade Spindle Complete		1

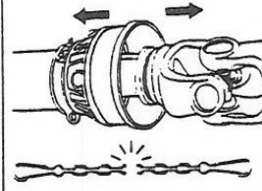
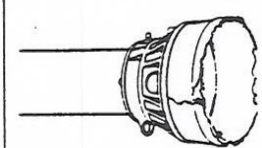
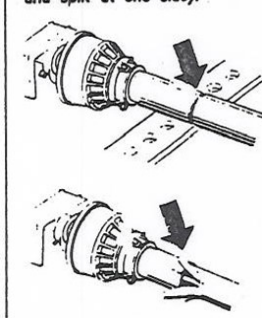

	AVOIDABLE DAMAGES	POSSIBLE CAUSES	CORRECTIVE ACTIONS
<b>Shield</b>  	-Excessive wear of shield bearings.  	-Insufficient lubrication.  -Incorrect chain mounting.  -Shield interfering with implement.	-Follow lubrication instructions.  -Mount chain to allow maximum angularity.  -Avoid contact of the shields with fixed parts of the machine or tractor.  -Replace shield bearings.
	-Chain, moving or failure.  	-Shield interfering with implement.  -Incorrect chain mounting	-Avoid contact of the shields with fixed parts of the machine or tractor.  -Mount chain to allow maximum angularity.  -Replace defective parts.
	-Guard cone damaged.  	-Guard cone in contact with components on the tractor and/or implement.  -Excessive angularity.	-Eliminate interference between guard cones and any part on the tractor and/or implement.  -Avoid excessive angle during cornering or when lifting or lowering the implement.  -Replace damaged guard cones.
	-Guard tubes damaged (deformed and split at one side).  	-Guards in contact with components on the tractor and/or implement.  -Guard tubes overlap too short or no overlap at all with extended P.T.O. drive shaft.	-Eliminate interference between guard cones and any part on the tractor and/or implement.  -Replace damaged tubes.  -Adjust guard tubes length with longer tubes.

Note: Shield bearings must be greased every 8 working hours.

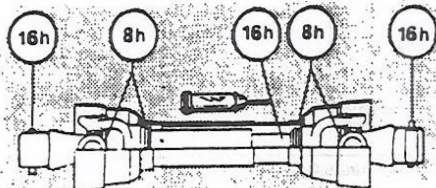

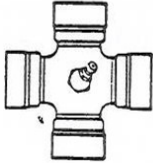

For any additional details (capacity, angle, length), please refer to catalogue.



Sold by:

	AVOIDABLE DAMAGES	POSSIBLE CAUSES	CORRECTIVE ACTIONS
<p><b>Cross kit</b></p> 	<p>-Cross arms broken.</p> 	<p>-Extreme torque peak or shock load.</p> <p>-Axial loads too high.</p>	<p>-Use appropriate safety device.</p> <p>-Change to a larger P.T.O. size.</p> <p>-Shorten P.T.O. shaft.</p> <p>-Replace defective cross bearings.</p>
	<p>-Bearing caps turning in their cross journal.</p> <p>-Overheated bearing caps.</p>	<p>-Excessive continuous torque and/or excessive working angle.</p> <p>-Inadequate greasing.</p>	<p>-Verify compatibility between shaft and working conditions.</p> <p>-Carefully follow greasing instructions.</p> <p>-Replace defective cross bearings.</p>
	<p>-Accelerated wear of cross kit.</p> 	<p>-Excessive continuous torque and/or excessive working angle.</p> <p>-Inadequate greasing.</p>	<p>-Verify compatibility between shaft and working conditions.</p> <p>-Carefully follow greasing instructions.</p> <p>-Replace defective cross bearings.</p>

Note: Cross bearings must be greased every 8 working hours.

	AVOIDABLE DAMAGES	POSSIBLE CAUSES	CORRECTIVE ACTIONS
<p><b>Telescopic tube</b></p>  	<p>-Telescopic tubes failure or twisting.</p> 	<p>-Extreme torque peak or shock load.</p> <p>-Short tube engagement.</p>	<p>-Use appropriate safety device.</p> <p>-Change to a larger P.T.O. size.</p> <p>-Replace the P.T.O. drive shaft with one having adequate length.</p> <p>-Replace defective tubes.</p>
	<p>-Accelerated wear of telescopic tubes.</p> 	<p>-Extreme load when sliding.</p> <p>-Short tube engagement.</p> <p>-Inadequate greasing.</p> <p>-Contaminants (sand, etc.).</p>	<p>-Change to a P.T.O. drive shaft with rilsan coated inner tube.</p> <p>-Replace the P.T.O. drive shaft with one having adequate length.</p> <p>-Carefully follow greasing instructions.</p> <p>-Replace defective tubes.</p>

Note: Telescopic tubes must be cleaned and greased every 16 working hours.

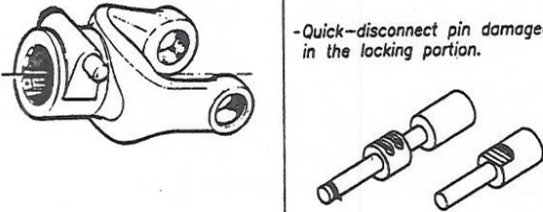
	AVOIDABLE DAMAGES	POSSIBLE CAUSES	CORRECTIVE ACTIONS
<b>Quick-disconnect yoke</b> 	<ul style="list-style-type: none"> <li>-Quick-disconnect pin tight or completely seized.</li> <li>-Quick-disconnect pin damaged (broken or bent).</li> <li>-Quick-disconnect pin damaged in the locking portion.</li> </ul>	<ul style="list-style-type: none"> <li>-Quick-disconnect pin dirty (insufficient maintenance).</li> <li>-Quick-disconnect pin defective (forced engagement, incorrect handling).</li> <li>-Excessive shaft length.</li> <li>-Axial loads too high.</li> </ul>	<ul style="list-style-type: none"> <li>-Clean, oil and follow service instructions.</li> <li>-Replace quick-disconnect pin.</li> <li>-Shorten shaft length (cut both telescopic tubes as well as shields and remove burrs).</li> <li>-Replace quick-disconnect pin.</li> <li>-Clean and grease telescopic tubes, and replace both tubes, if necessary.</li> <li>-Replace quick-disconnect pin.</li> </ul>

Note: Quick-disconnect pins must be cleaned and greased every 16 working hours.

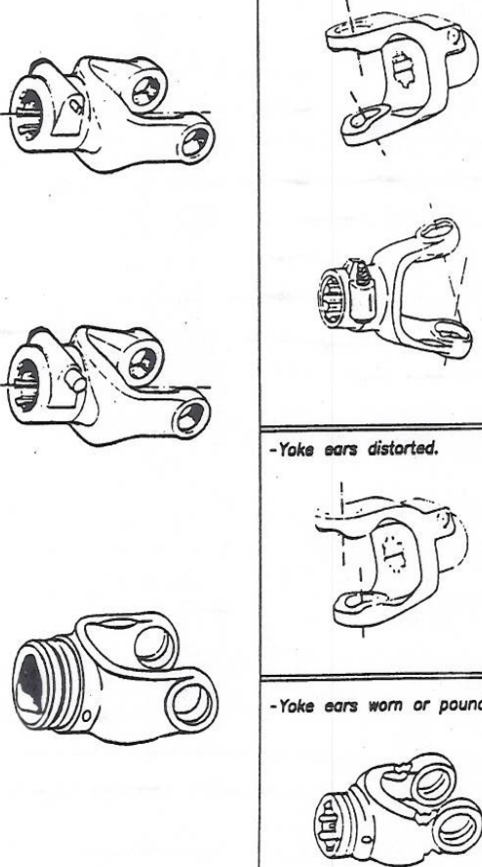
	AVOIDABLE DAMAGES	POSSIBLE CAUSES	CORRECTIVE ACTIONS
<b>Yoke</b> 	<ul style="list-style-type: none"> <li>-Yoke ears deformation.</li> </ul>	<ul style="list-style-type: none"> <li>-Excessive shaft length.</li> <li>-Axial loads too high.</li> <li>-Excessive working angle and torque.</li> </ul>	<ul style="list-style-type: none"> <li>-Shorten shaft length (cut both telescopic tubes as well as shields and remove burrs).</li> <li>-Replace defective yokes.</li> <li>-Clean and grease telescopic tubes, and replace both tubes, if necessary.</li> <li>-Replace defective yokes.</li> <li>-Verify compatibility between shaft and working conditions (torque vs angle).</li> <li>-Disengage tractor P.T.O. during cornering or when lifting or lowering the implement.</li> <li>-Change to a larger P.T.O. size.</li> <li>-Replace defective yokes.</li> </ul>
	<ul style="list-style-type: none"> <li>-Yoke ears distorted.</li> </ul>	<ul style="list-style-type: none"> <li>-Overload caused by high starting and peak torques.</li> </ul>	<ul style="list-style-type: none"> <li>-Engage P.T.O. more carefully.</li> <li>-Use appropriate safety device.</li> <li>-Replace defective yokes.</li> </ul>
	<ul style="list-style-type: none"> <li>-Yoke ears worn or pounded.</li> </ul>	<ul style="list-style-type: none"> <li>-Excessive working angle.</li> </ul>	<ul style="list-style-type: none"> <li>-Avoid excessive working angle.</li> <li>-Disengage tractor P.T.O. during cornering.</li> <li>-Replace defective yokes.</li> </ul>

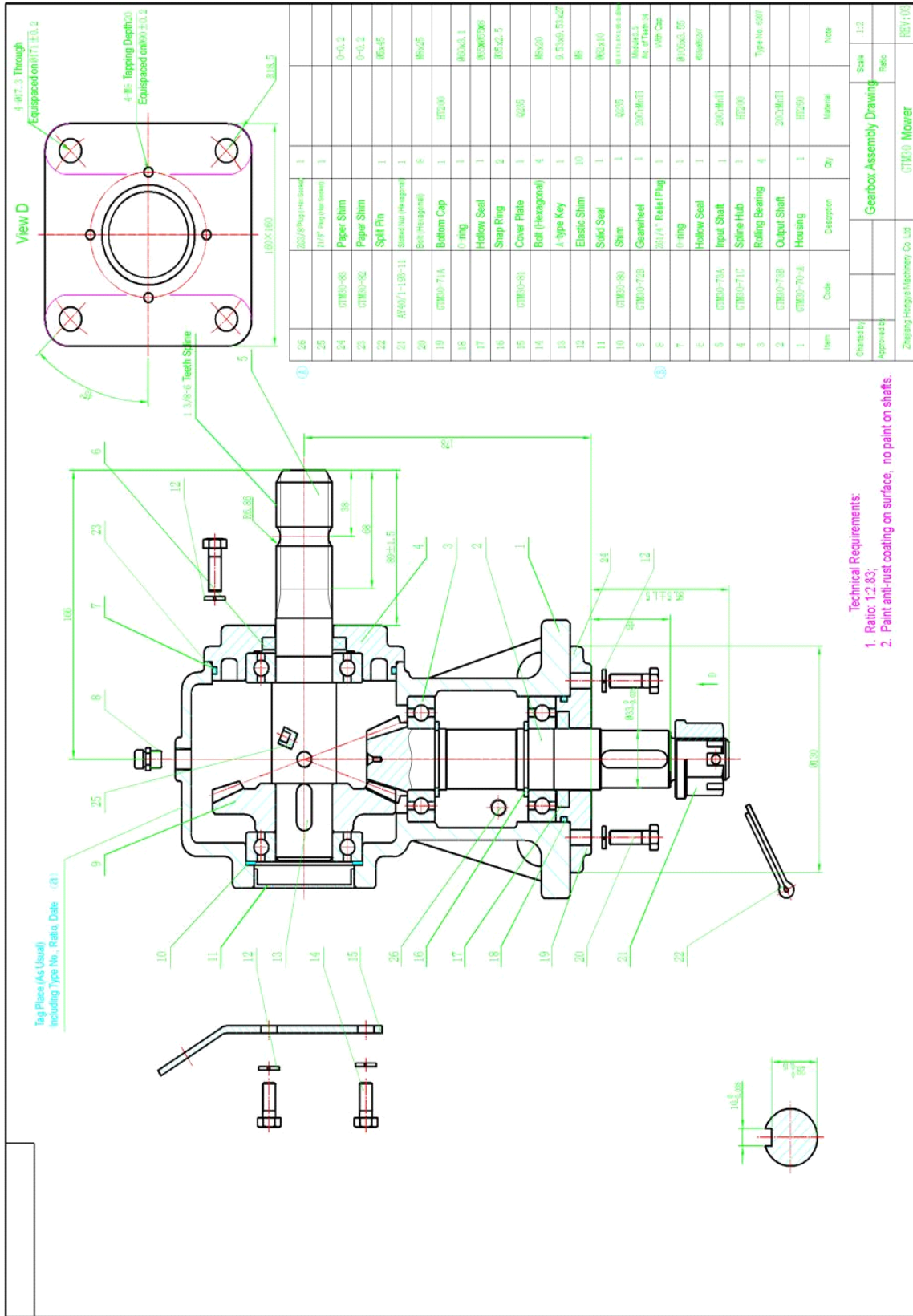

**Increasing agricultural productivity since 1974**

# **Belco Resources Equipment**

**P.O. Box 8164  
Rocky Mount, NC 27804  
[www.BR-Equipment.com](http://www.BR-Equipment.com)**

**Tel: 252-442-0700  
Fax: 252-442-0787  
[Sales@BRGlimited.com](mailto:Sales@BRGlimited.com)**

